



[www.falconequipment.com](http://www.falconequipment.com)

879 South 4400 West

Salt Lake City, UT 84104

Phone: 888-987-7894



Model #HR-72

### Cooling

Temperature Range	33°F - 40°F
Refrigerant	R290
Max. Ambient Temperature	90°F
Defrosting	Automatic
Temperature Controller	Digital
Horsepower	4/5

### Electrical

Voltage	115
Amps	6.2
Hz	60
Phase	1
Plug Type	NEMA-6-20P
Electrical Cord Length	96"

### Standard Features - Reach-in Refrigerator #HR-72

- Self-closing doors with convenient stay-open feature
- Easy-to-clean 430 series stainless steel exterior
- Painted Aluminum exterior
- "No stoop" lower shelf; Easily accessible condenser coil for cleaning, and easy service access
- Equipped with casters
- Temperature range of 33°F - 40°F
- 9 shelves included; versatile shelf slide design also accepts full size food pans
- Environmentally-safe R290 refrigerant
- Digital temperature controller with automatic defrost function
- 115V; 4/5 HP
- ETL Safety & Sanitation Listed
- Conforms to UL STD. 471, Certified to CSA STD. C22. 2No.120
- Conforms to NSF/ANSI STD. 7.

### Construction

Exterior Material	430 Stainless Steel
Interior Material	Painted aluminum
Insulation Material	Foamed-In-Place Polyurethane
Shelf Size	(6) 23.2"W x 23.6"D & (3) 25.1"W x 23.6"D
Shelf Material	Epoxy-Coated Steel
Shelf Load Capacity	88 lbs.

### Dimensions

Exterior Dimensions	80.9"W x 32.2"D x 82.5"H
Interior Dimensions	76.3"W x 27.1"D x 51.6"H
Shipping Dimensions	83-1/2"W x 34-3/4"D x 85-1/2"H
Net Volume	72.1 cu. ft.
Net Weight	615 lb.
Gross Weight	693 lb.



Parts & Labor

Compressor

### PLAN VIEW

Front View

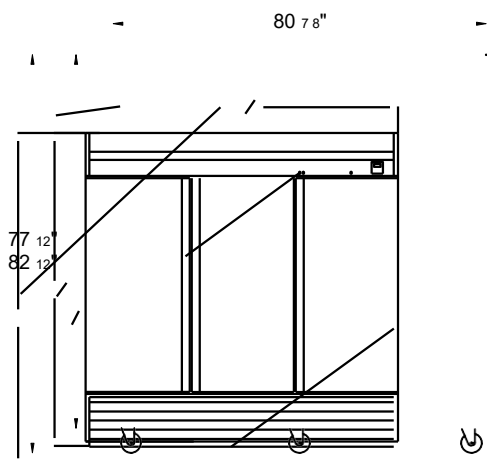

Side View

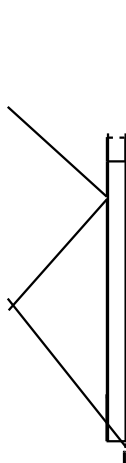

Top View

