



Model #HR-19

## Standard Features - Reach-in Refrigerator #HR-19

- Self-closing door with convenient stay-open feature
- Easy-to-clean 430 series stainless steel exterior
- Painted aluminum interior
- Equipped with casters
- "No stoop" lower shelf; Easily accessible condenser coil for cleaning, and easy service access
- Temperature range of 33°F - 40°F
- 3 shelves included: versatile shelf slide design also accepts full size food pans
- Environmentally-safe R290 refrigerant
- Digital temperature controller with automatic defrost function
- 115V; 1/3 HP ETL Safety & Sanitation Listed
- ETL listed. Conforms to UL STD. 471, Certified to CSA STD. C22.2No.120
- Conforms to NSF/ANSI STD. 7.

## Construction

Exterior Material 430 Stainless Steel  
 Interior Material Painted aluminum  
 Insulation Material Foamed-In-Place Polyurethane  
 Shelf Size (3) 23.4"W x 19.3"D  
 Shelf Material Epoxy coated steel  
 Load Capacity 88lb.

## Cooling

Temperature Range	33°F - 40°F
Refrigerant	R290
Max. Ambient Temperature	90°F
Defrosting	Automatic
Temperature Controller	Digital
Horsepower	1/3

## Electrical

Voltage	115
Amps	3.1
Hz	60
Phase	1
Plug Type	NEMA-5-15P
Electrical Cord Length	96"

## Dimensions

Exterior Dimensions	29"W x 25-1/2"D x 82-1/2"H
Interior Dimensions	24.4"W x 20.4"D x 51.6"H
Shipping Dimensions	31"W x 27"D x 83"H
Net Volume	17.3 cu. ft.
Net Weight	236 lbs.
Gross Weight	268lbs.



Parts & Labor

Compressor

## PLAN VIEW

Front View

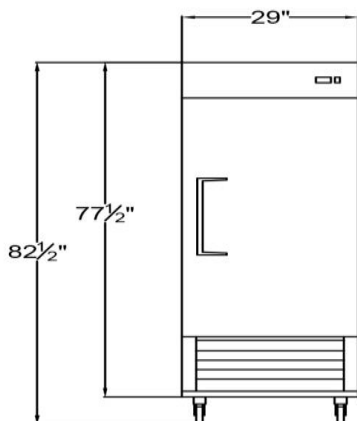

Side View



Top View

